

**Class X Session 2024-25**  
**Subject - Science**  
**Sample Question Paper - 2**

**Time Allowed: 3 hours**

**Maximum Marks: 80**

**General Instructions:**

1. This question paper consists of 39 questions in 5 sections.
2. All questions are compulsory. However, an internal choice is provided in some questions. A student is expected to attempt only one of these questions.
3. Section A consists of 20 objective-type questions carrying 1 mark each.
4. Section B consists of 6 Very Short questions carrying 02 marks each. Answers to these questions should be in the range of 30 to 50 words.
5. Section C consists of 7 Short Answer type questions carrying 03 marks each. Answers to these questions should be in the range of 50 to 80 words.
6. Section D consists of 3 Long Answer type questions carrying 05 marks each. Answers to these questions should be in the range of 80 to 120 words.
7. Section E consists of 3 source-based/case-based units of assessment of 04 marks each with sub-parts.

**Section A**

1. A student took Cu, Al, Fe and Zn strips separately in four test tubes labelled I, II, III and IV. He added 10 mL of [1]  
freshly prepared ferrous sulphate solution to each test tube as shown below:

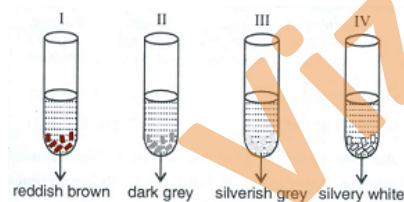

Black residue would be obtained in test tubes

- |               |                 |
|---------------|-----------------|
| a) II and IV  | b) I, II and IV |
| c) II and III | d) III and IV   |
2. Which of the following metals **do not** corrode in moist air? [1]
- |           |           |
|-----------|-----------|
| a) Iron   | b) Silver |
| c) Copper | d) Gold   |
3. Which one of the following types of medicines is used for treating indigestion? [1]
- |                |               |
|----------------|---------------|
| a) Antacid     | b) Antiseptic |
| c) Antibiotics | d) Analgesic  |
4. Which of the following is not an allotropic form of carbon? [1]

- a) Diamond  
 b) Fluorine  
 c) Graphite  
 d) Fullerene

5. What is shown in the experiment given below: [1]

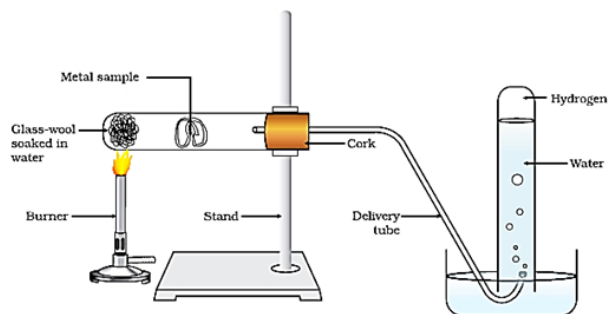

- a) Reaction of metals with salt solutions  
 b) Heating a salt sample on a spatula  
 c) Action of steam on a metal  
 d) Testing the conductivity of a salt solution

6. If copper is kept open in air, it slowly loses its shining brown surface and gains a green coating. It is due to the formation of [1]

- a)  $\text{CuCO}_3$   
 b)  $\text{CuO}$   
 c)  $\text{CuSO}_4$   
 d)  $\text{Cu}(\text{NO}_3)_2$

7. The structural formula of an ester from which an acid and an alcohol is formed is as follows. Name the acid and the alcohol. [1]

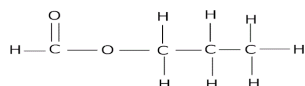

- a) Formic acid, Ethanol  
 b) Ethanoic acid, Ethanol  
 c) Propanoic acid, Methanol  
 d) Formic acid, Propanol

8. Anaerobic process [1]

- a) takes place in yeast during fermentation  
 b) produces ethanol, oxygen, and energy  
 c) takes place in the presence of oxygen  
 d) produces only energy in the muscles of human beings

9. The egg of an animal contains 10 chromosomes, of which one is X-chromosome. How many autosomes would be there in the karyotype of this animal? [1]

- a) 9  
 b) 18  
 c) 8  
 d) 20

10. Characters transmitted from parents to offspring are present in [1]

- a) Cytoplasm  
 b) Genes  
 c) Ribosome  
 d) Golgi bodies

11. In a plant, smooth seeds(S) are dominant over wrinkled seeds(s) and green seeds (G) are dominant over yellow seeds (g). A plant homozygous for smooth and green seed is crossed with a plant having wrinkled and yellow seeds. The  $F_1$  offspring are self crossed to produce  $F_2$  generation. If a total of 160 offspring are produced, how many plants are expected to be having wrinkled and green seeds in  $F_2$  generation, according to a typical Mendelian cross? [1]



- c) A is true but R is false. d) A is false but R is true.
20. **Assertion (A):** The second trophic level of a food chain operating in a grassland is mostly occupied by a carnivore. [1]  
**Reason (R):** Carnivores feed upon herbivores and are secondary consumers.
- a) Both A and R are true and R is the correct explanation of A. b) Both A and R are true but R is not the correct explanation of A.
- c) A is true but R is false. d) A is false but R is true.

### Section B

21. A mixture of oxygen and ethyne is burnt for welding. Can you tell why a mixture of ethyne and air is not used? [2]
22. What will happen if the fallopian tubes are partially blocked and the ovulated eggs are prevented from reaching the uterus? [2]
23. Chlorophyll is necessary for photosynthesis. Why? [2]

OR

- Why is it not advisable to sleep under a tree at night while resting under it during mid-day is not bad?
24. An object is placed at a distance of 30 cm from a concave lens of focal length 15 cm. List four characteristics (nature, position, etc.) of the image formed by the lens. [2]
25. List two reasons to show that the existence of decomposers is essential in an ecosystem. [2]

OR

- Microorganisms are often referred to as the 'scavengers of the environment.' Explain.
26. Which part of the eye controls the size of the pupil? [2]

### Section C

27. i. Which types of metals can be obtained in their pure form by just heating their oxides in air? Give one example. [3]  
 ii. Consider the reaction given below used to obtain Manganese metal in pure form:  

$$3\text{MnO}_2(\text{s}) + 4\text{Al}(\text{s}) \longrightarrow 3\text{Mn}(\text{l}) + 2\text{Al}_2\text{O}_3(\text{s}) + \text{Heat}$$
 a. What type of reaction is it?  
 b. What is the role of aluminium in this reaction?
28. Carbon cannot reduce the oxides of sodium, magnesium, and aluminium to their respective metals. Why? Where are these metals placed in the reactivity series? How are these metals obtained from their ores? Take an example to explain the process of extraction along with chemical equations. [3]

OR

- What are the various methods used for concentration of ore/Ore dressing?
29. Define nutrition. What are the different modes of nutrition? [3]
30. i. In humans, if gene B gives brown eyes and gene b gives blue eyes, what will be the colour of eyes of the persons having the following combination of genes? (a) Bb (b) bb (c) BB [3]  
 ii. What do you class this trait of eye colour in human? Explain.
31. Distinguish between real image and virtual image. [3]
32. Given in fig. is the circuit diagram in which three resistors of  $1\Omega$ ,  $2\Omega$  and  $3\Omega$  are connected to cell of e.m.f. 2V and internal resistance  $0.5\Omega$ . [3]  
 i. Calculate the total resistance of the circuit.

ii. What is the reading of ammeter and What will be ammeter reading if an exactly similar cell is connected in

series with the given cell ?

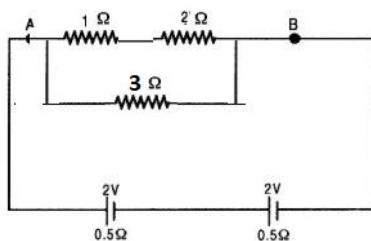

33. a. What is the heating effect of electric current? [3]  
b. Write an expression for the amount of heat produced in a resistor when an electric current is passed through it stating the meanings of the symbols used.  
c. Name two appliances based on heating effect of electric current.

#### Section D

34. a. Distinguish between esterification and saponification reactions with the help of chemical equations for each. [5]  
b. With a labelled diagram describe in brief an activity to show the formation of an ester.

OR

What are detergents chemically? List two merits and two demerits of using detergents for cleansing. State the reason for the suitability of detergents for washing, even in the case of water having calcium and magnesium ions.

35. Give reason for the following: [5]  
a. During reproduction inheritance of different proteins will lead to altered body designs.  
b. Fertilization cannot take place in flowers if pollination does not occur.  
c. All multicellular organisms cannot give rise to new individuals through fragmentation or regeneration.  
d. Vegetative propagation is practised for growing only some type of plants.  
e. The parents and off-springs of organisms reproducing sexually have the same number of chromosomes.

OR

Explain briefly movements in plants.

36. An object is placed at a distance of 30 cm from a concave lens of focal length 30 cm. [5]  
i. Use lens formula to determine the distance of the image from the lens.  
ii. List four characteristics of the image (nature position, size, erect/inverted) in this case.  
iii. Draw a labelled diagram to justify your answer of part (ii)

OR

- i. What is meant by power of a lens? Define its SI unit.  
ii. You have two lenses A and B of focal lengths +10 cm and - 10 cm, respectively. State the nature and power of each lens. Which of the two lenses will form a virtual and magnified image of an object placed 8 cm from the lens? Draw a ray diagram to justify your answer.

#### Section E

37. **Read the text carefully and answer the questions:** [4]

Copper sulphate crystal contains water of crystallisation when the crystal is heated the water is removed and salt turns white. The crystal can be moistened again with water. The water of crystallisation is the fixed number of water molecules present in 1 formula unit of copper sulphate. On heating gypsum at 373K, it loses water

molecules and became calcium sulphate hemihydrate.

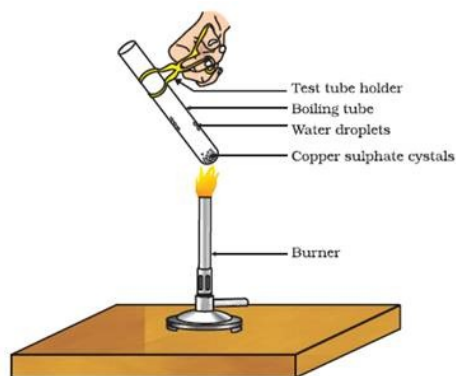

- If the crystal is moistened with water, then which colour of the crystal reappears?
- What is the commercial name of calcium sulphate hemihydrate?

**OR**

How many water molecules are present in one formula unit of copper sulphate?

38. **Read the text carefully and answer the questions:**

[4]

Animals have a nervous system for controlling and coordinating the activities of the body. But plants have neither a nervous system nor muscles. So, how do they respond to stimuli? When we touch the leaves of a chui-mui (the 'sensitive' or 'touch-me-not' plant of the Mimosa family), they begin to fold up and droop. When a seed germinates, the root goes down, the stem comes up into the air. What happens? Firstly, the leaves of the sensitive plant move very quickly in response to touch.

There is no growth involved in this movement. On the other hand, the directional movement of a seedling is caused by growth. If it is prevented from growing, it will not show any movement.

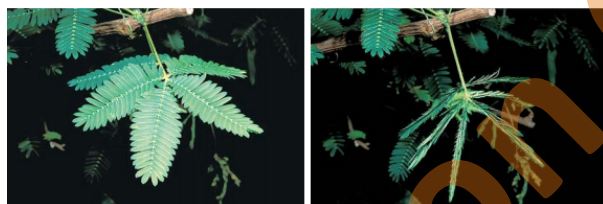

- Write the types of movement.
- Give an example of a plant hormone that promotes growth.
- What is the function of the nervous system?

**OR**

How is the movement of leaves of the sensitive plant different from the movement of a shoot towards light ?

39. **Read the text carefully and answer the questions:**

[4]

An insulated copper wire wound on a cylindrical cardboard tube such that its length is greater than its diameter is called a solenoid. When an electric current is passed through the solenoid, it produces a magnetic field around it. The magnetic field produced by a current-carrying solenoid is similar to the magnetic field produced by a bar magnet. The field lines inside the solenoid are in the form of parallel straight lines. The strong magnetic field produced inside a current-carrying solenoid can be used to magnetize a piece of a magnetic material like soft iron when placed inside the solenoid. The strength of the magnetic field produced by a current-carrying solenoid

is directly proportional to the number of turns and strength of the current in the solenoid.

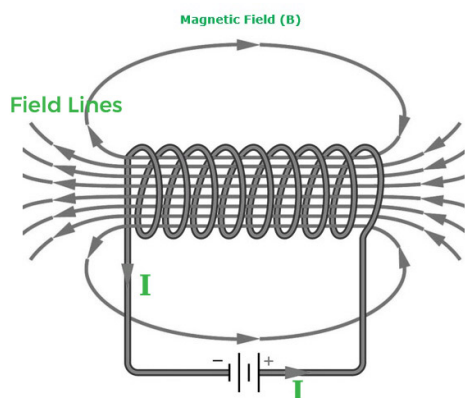

- What would be the strength of the magnetic field inside a long current-carrying straight solenoid?
- Which end is north and which end is south pole when current flows through a solenoid?
- A long solenoid carrying a current produces a magnetic field  $B$  along its axis. If the current is double and the number of turns per cm is halved, then what will be the new value of the magnetic field?

**OR**

A soft iron bar is enclosed by a coil of insulated copper wire as shown in the figure. When the plug of the key is closed, then where would the face B of the iron bar be marked?

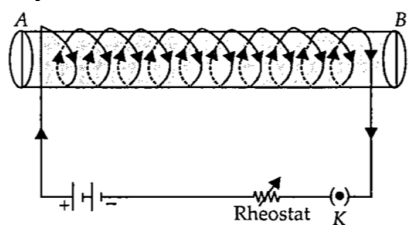

# Solution

## Section A

1. (a) II and IV

**Explanation:** Black residue would be obtained in test tubes II and IV because Al and Zn will displace iron from  $FeSO_4$  to form black residue as these are more reactive than iron.

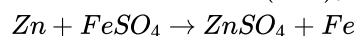
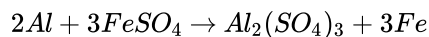

2.

(d) Gold

**Explanation:** Gold is a noble metals i.e., very less reactive metals and hence they do not get corrode easily in moist air.

3. (a) Antacid

**Explanation:** Antacids are mild bases which are given to a person suffering from acidity as acids reacts with bases to form salt and water. The excess acid present in the stomach is neutralised by the bases present in antacids and relieve indigestion.

4.

(b) Fluorine

**Explanation:** Fluorine

5.

(c) Action of steam on a metal

**Explanation:** Action of steam on a metal.

6. (a)  $CuCO_3$

**Explanation:** Copper gets green coating due to the basic copper carbonate formation and is a mixture of copper carbonate and copper hydroxide when it reacts with carbon dioxide gas and moisture present in the air. This is called tarnishing of copper.

The reaction is as follows:

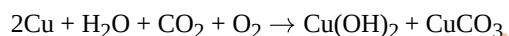

7.

(d) Formic acid, Propanol



The ester is  $HCOOCH_2CH_2CH_3$ . The product  $HCOOH$  is formic acid or methanoic acid (carboxylic acid) and  $CH_3CH_2CH_2OH$  is propanol (alcohol).

8. (a) takes place in yeast during fermentation

**Explanation:** takes place in yeast during fermentation

9.

(b) 18

**Explanation:** Karyotype is the number and appearance of chromosomes in a nucleus of somatic cell. Somatic cells are diploid cells which make up the body. They have two sets of chromosomes. So, if an egg cell (gamete cell) which is a haploid cell (with single set of chromosomes) has 10 chromosome, then number of chromosomes present in a somatic cell will be 20 chromosomes. As egg cells are produced by female body, then among 20 chromosomes, two X chromosomes will be sex chromosome. So, karyotype of that animals will be showing 18 autosomes.

10.

(b) Genes

**Explanation:** The characteristics or traits of parents are transmitted to their progeny (offsprings) through genes present on their chromosomes

11.

(c) 30

**Explanation:** 30



12. **(d)** Cytoplasm  
**Explanation:** When there is a lack of oxygen Breakdown of Pyruvate takes place in the cytoplasm of muscle cells leading to the formation of Lactic acid.
13. **(d)** Same at all points  
**Explanation:** Same at all points
14. **(a)** nichrome  
**Explanation:** The elements of electric heating devices are made using nichrome.
15. **(d)** Incineration  
**Explanation:** Incineration is the process of burning substances under aerobic conditions at high temperature (usually more than 1000°C) in a closed unit called incinerator.
16. **(a)** Groups (a), (c) and (d)  
**Explanation:**  
The waste that is generated may be biodegradable or non-biodegradable. Substances that are broken down by biological processes are said to be biodegradable. Grass, flowers, leather, wood, fruit peels, cake and lime-juice are all biodegradable. Substances that are not broken down by biological processes are said to be non-biodegradable. Plastic is non-biodegradable. Plastic is inert and persists in the environment for a long time.
17. **(a)** Both A and R are true and R is the correct explanation of A.  
**Explanation:** Both A and R are true and R is the correct explanation of A.
18. **(b)** Both A and R are true but R is not the correct explanation of A.  
**Explanation:** Regeneration is the process which involves repair of damaged cells/tissue or replacement or redevelopment of broken body part or reconstruction of whole body from a small body fragment. The simple animals like Hydra and Planaria show regeneration. It means if Hydra or Planaria somehow get cut into a number of pieces, then each body piece can grow into a complete organism.
19. **(d)** A is false but R is true.  
**Explanation:** A is false but R is true.
20. **(d)** A is false but R is true.  
**Explanation:** The second trophic level of a food chain is occupied by herbivores that feed on plants or producers that are present in first trophic level.

### Section B

21. Ethyne is an unsaturated hydrocarbon. Since it has high carbon content, it burns in air with a sooty flame due to the presence of unburnt carbon in it. Due to its incomplete combustion, heat produced is not sufficient to attain the high temperature needed for welding. In order to ensure complete combustion and to obtain a high temperature needed for welding, a mixture of ethyne and oxygen is used.
22. Fertilization may take place but the zygote may develop in the tube instead of uterus.
23. The chlorophyll traps the solar energy and converts it into chemical energy which takes part the dark reaction of photosynthesis to form glucose. Hence chlorophyll is necessary for photosynthesis.

OR

During the day, in presence of sunlight, the plants use up the  $\text{CO}_2$  and release  $\text{O}_2$  in the process of photosynthesis. But during night, plants won't perform photosynthesis so they are unable to use the  $\text{CO}_2$  and this further leads to increase in the proportion of  $\text{CO}_2$  in the air. During night the trees breathe in oxygen and release  $\text{CO}_2$ . If one sleeps under the trees, the amount of increased  $\text{CO}_2$  in the air around will certainly affect the health. So it is inadvisable to sleep under trees during night. He suffers from suffocation. He feels excess weight on his chest. For this reason, some rural people imagine and fear that ghosts would come and sit on their chests if they sleep under Peepal or Banyan trees.

24. Object distance,  $u = -30$  cm

Focal length of concave lens =  $-15$  cm

We know that,  $\frac{1}{v} - \frac{1}{u} = \frac{1}{f}$

$$\frac{1}{v} - \frac{1}{-30} = \frac{1}{-15}$$

$$\frac{1}{v} = -\frac{1}{15} - \frac{1}{30}$$

$$\frac{1}{v} = \frac{-2-1}{30} = \frac{-3}{30} = \frac{-1}{10}$$

$v = -10$  cm .

#### Characteristics of image:

- The image is formed at a distance of 10 cm from the concave lens on the left side.
  - Image formed is virtual.
  - Image formed is erect.
  - The size of the image formed is diminished.
25. Microorganisms like bacteria and fungi which helps in the breakdown of organic matter or biomass of dead plants and animals into simple inorganic raw materials and replenish the environment are termed as decomposers. Their existence is thus, essential in an ecosystem because
- They help in the natural replenishment of soil.
  - They help in keeping the environment clean as they reduce environmental pollution.

OR

Scavengers feed upon discarded and dead waste. Micro organisms are called scavengers of the environment because they decompose dead bodies of plants and animals present in the soil and help in cleaning the environment by removing waste products. They lie at the top of food chain.

26. Iris

#### Section C

27. i. Metals low in activity series can be reduced to pure metals just by heating their oxides in presence of air, example mercury (Hg):

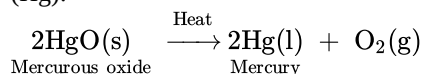

- a. The given reaction is a displacement reaction.
  - b. Aluminium is more reactive than manganese used as a reducing agent, as Al is capable of replacing Mn from  $\text{MnO}_2$ .
28. Oxides of sodium, magnesium and aluminium are very strong oxides as these metals are very reactive metals, but carbon is not a strong reducing agent and hence carbon cannot reduce the oxide of sodium, magnesium and aluminium to their respective metal. In the reactivity series, sodium, magnesium and aluminium are placed in the upper portion and they are very reactive in nature and carbon is less reactive.

$\text{K} > \text{Na} > \text{Ca} > \text{Mg} > \text{Al} > \text{C} > \text{Zn} > \text{Fe}$

Oxides of reactive metals are directly put into the electrolytic reduction process to obtain the pure metal.

For the oxide of a reactive metal like aluminium oxide, as the metal is already in its oxide state so, it is directly put for the electrolytic reduction process. In this process, graphite electrodes are used as anode and cathode in the electrolytic chamber. Pure aluminium is attracted to the cathode, which is a lining of graphite. The oxygen is attracted to the anode and bubbles through the solution.

**Cathode reaction:** At the cathode reduction of aluminium takes place and aluminium is discharged

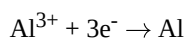

**Anode reaction:** At the anode oxidation takes place and oxygen gas is evolved.

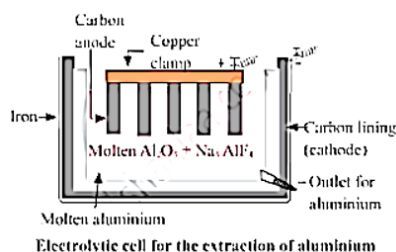
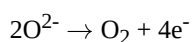

OR

Concentration of Ore: The process of removal of unwanted impurities like sand, rocky material, earthy particles etc. from the ore is called ore concentration or ore dressing. The finely ground ore is concentrated by any of the following processes:

- i. Hydraulic washing: This method depends upon the difference in the densities of the ore particles and the impurities (gangue). The crushed and powdered ore is taken in large wooden tables with small obstacles. A stream of water is passed over the shaking table. The lighter impurities are washed away with the running stream of water while the heavier ore particles are left behind. This method of concentration is usually applicable to oxide ores.
- ii. Froth floatation process: This method is used for the extraction of those metals in which the ore particles are preferentially wetted by oil and gangue by water. In this method, the powdered ore is mixed with water containing small quantities of oil (pine oil or eucalyptus oil) in a large tank (Fig.). The water is agitated by blowing air violently when a froth (or foam) is formed. The froth carries the lighter ore particles along with it to the surface. The heavier impurities are left behind in water and these settle to the bottom. Since the ore particles float with the froth at the surface, this process is called froth floatation process. The froth at the surface is transferred into another tank. The froth is broken by adding some acid and ore particles are separated by filtration and dried. For example, the froth floatation process is commonly used for the sulphide ores of copper, zinc, lead etc.

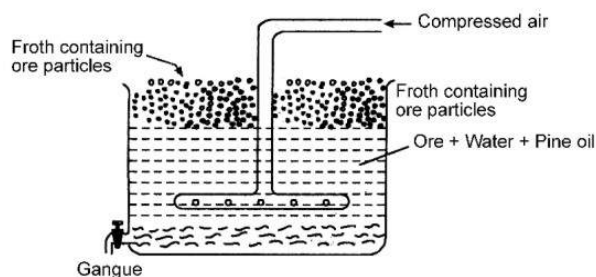

- iii. Magnetic separation: The ores which are attracted by a magnet can be separated from the non-magnetic impurities with the help of magnetic separation method. For example, this method is used for the concentration of haematite, an ore of iron. It consists of a leather belt moving over two rollers, one of which is magnetic in nature. This is shown in the figure. The powdered ore is dropped over the moving belt at one end. At the other end, the magnetic portion of the ore is attracted by the magnetic roller and falls nearer to the roller while the non-magnetic impurities fall farther off.

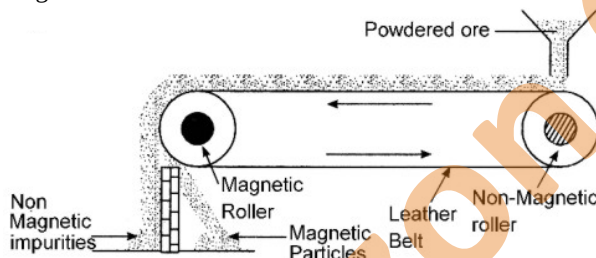

29. **Nutrition:** The sum total of processes by which living organisms obtain food materials and prepare them for use in the growth, repair and providing energy is termed nutrition.

Nutrition is of two types: 1) Autotrophic nutrition, 2) Heterotrophic nutrition.

**1) Autotrophic nutrition:** The mode of nutrition in which an organism prepares its own food is called autotrophic nutrition.

Mostly green plants have the ability to manufacture their own organic food due to the presence of chlorophyll. They take up  $\text{CO}_2$  and  $\text{H}_2\text{O}$  and manufacture carbohydrates in the presence of sunlight process called as photosynthesis. Such organisms are called autotrophs and their mode of nutrition is called autotrophic.

**2) Heterotrophic nutrition:** The mode of nutrition in which an organism takes food from another organism is called heterotrophic nutrition. In this type of nutrition, the animals derive organic food materials by consuming bodies or products of other living or dead plants or animals.

30.
  - i. Bb will have brown eyes.  
bb will have blue eyes.  
BB will have brown eyes.
  - ii. Eye colour in humans is an inherited trait. These are traits that are present in the DNA of an organism and are passed on to their progeny.

31.	<b>Real Image</b>	<b>Virtual Image</b>
	1. It is formed by the actual meeting of reflected (or refracted) ray.	1. It is formed when reflected (or refracted) rays appear to meet when produced backward

2.It can be obtained on the screen.	2.It cannot be obtained on the screen.
3.It is always inverted.	3.It is always erect.
4.It is formed by concave mirror or convex lens.	4.It is formed by concave, convex and plane mirror(or concave and convex lens.)

32. Resis~~OK~~tance,  $1\Omega$  and  $2\Omega$  are in series and combined resistance i.e.  $1 + 2 = 3\Omega$  in parallel with  $3\Omega$ .

Hence total resistance of the combination is  $\frac{1}{R} = \frac{1}{3} + \frac{1}{3} = \frac{2}{3}$  or  $R = \frac{3}{2} = 1.5\Omega$

i. Total resistance of the circuit =  $R + r = 1.5 + 0.5 = 2\Omega$

ii. Total current through ammeter =  $\frac{E}{R + r} = \frac{2}{2} = 1A$

iii. In second case total e.m.f. =  $2 + 2 = 4V$

Total resistance =  $1.5 + 0.5 + 0.5 = 2.5\Omega$

Current through circuit in second case =  $\frac{4}{2.5} = \frac{40}{25} = \frac{8}{5} = 1.6 A$

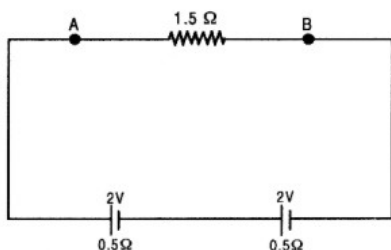

33. a. When an electric current passes through a conductor (like a high resistance wire) the conductor becomes hot after some time and produces heat. This is called heating effect of Electric Current.

**Ex:** A bulb becomes hot after its use for some time. This is because of heating effect of electric current.

b. We Know that

$$H = P \times t$$

$$H = \frac{\text{Energy}}{\text{Time}} \times t$$

$$\therefore \text{Energy} = V.Q$$

$$H = \frac{V.Q.t}{t}$$

$$H = Vit$$

$$\therefore V = IR$$

$$H = I^2Rt$$

Other form

$$H = V \left[ \frac{V}{R} \right] t$$

Where

I = Current

R = Resistance

t = Time

c. Two devices which work on the heating effect of electric current are:

i. Electric heater

ii. Electric iron

#### Section D

34. ○ Here the difference between esterification and saponification reactions

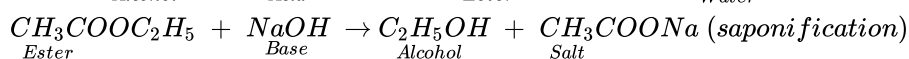

- Diagram for esterification

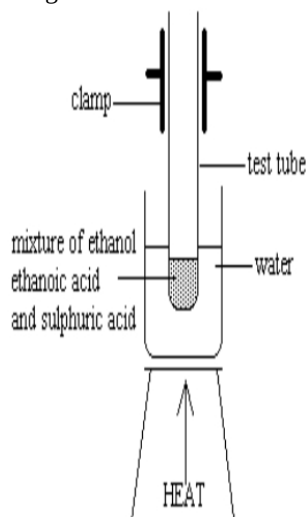

#### Description

1mL ethanol, 1mL glacial acetic acid and a few drops of conc.  $H_2SO_4$

↓

Warmed in a water bath

↓

Water is poured into the beaker

↓

Fruity smell is produced

OR

Detergents are chemically ammonium or sulphonate salts of long chain carboxylic acids.

Merits:

- Detergents can work well with both hard water and soft water.
- Detergents are more effective than soaps.
- Detergents contain synthetic chemicals so tend to provide more cleaning power.
- Detergents are made with chemical substances so they can be modified for specific purposes such as laundry detergents etc.
- Detergents are more easily soluble in water.

Demerits:

- They are expensive.
- They can create water pollution.
- Detergents are formed with a synthetic chemical with few natural sources therefore they are usually non-biodegradable.
- They can cause soil pollution.
- Detergent poisoning occurs when someone swallows cationic or anionic detergents, reports Medline Plus.

Detergents are suitable for hard water having Magnesium and Calcium ions because they do not form insoluble salts with these ions.

- Reproduction at its most basic level involves making copies of the blueprints of body design. The DNA in the cell nucleus is the information source for making proteins. If the information is changed, different proteins will be made. Different proteins will eventually lead to altered body designs.
  - In flowering plants, male gametes are produced in the pollen grains inside the anther. Pollination brings the pollen grains having male gametes from the anther to the stigma. Upon successful arrival of pollen grains on the stigma, a pollen tube is formed where they take male gamete to the female gamete or egg present in the ovule for fertilisation.
  - The body's organs are made of tissue and specialised cells, complex multicellular creatures cannot give birth to new life. Multicellular organisms cannot reproduce by regeneration of a portion of some tissue because of their high level of specialisation.
  - Vegetative propagation is the ability of the plants to reproduce by producing new plants from the vegetative plant parts such as leaf, stem, or roots under appropriate conditions. This method is the only means of reproduction for some seedless plant varieties such as banana, rose, and jasmine.
  - Gametes of sexually-reproducing animals have half the number of chromosomes as that of the parents. Thus, during fertilisation, when two gametes i.e. male and female gametes, fuse, the offspring produced will have the same amount of DNA

or the same number of chromosomes as that of the parent.

OR

## Plant Movement

### Tropic movement or tropism

Directional movement of specific part of plant in response to external stimuli is called **tropism**.

These movements are very slow. The movement of plant part can be either towards or away from stimulus.

If the movement of plant is towards stimulus, it is called **positive stimulus**.

If the movement of plant is away from stimulus, it is called **negative stimulus**.

**1) Phototropism:** It is the directional movement of plant part in response to light stimulus.

If plant part move towards light it is called as **positive phototropism**.

For Ex: Stem or shoot

If plant part move away from light it is called as **negative phototropism**.

For Ex: Roots

**2) Geotropism :** It is the response to gravity.

If the plant part moves in the direction of gravity it is called **positive geotropism**

For Ex: Roots grow downwards.

If the plant part moves against the direction of gravity it is called **negative geotropism**.

For Ex: Stem grows upwards

**3) Chemotropism :** Response to chemical stimuli.

If Plant part move towards chemical stimuli it is **positive chemotropism**

If plant part move away from chemical stimuli it is **negative chemotropism**.

**4) Hydrotropism :** Response to water.

36. i.  $u = -30$  cm  $f = -30$  cm  $v = ?$   $m = ?$

$$\begin{aligned}\frac{1}{f} &= \frac{1}{v} - \frac{1}{u} \\ \therefore \frac{1}{v} &= \frac{1}{f} + \frac{1}{u} \\ &= \frac{1}{(-30 \text{ cm})} + \frac{1}{(-30 \text{ cm})} \\ \frac{1}{v} &= -\frac{1}{30} - \frac{1}{30} \\ &= \frac{-2}{30} \\ \therefore v &= -15 \text{ cm} \\ m &= \frac{v}{u} \\ &= \frac{(-15 \text{ cm})}{(-30 \text{ cm})} = -\frac{1}{2}\end{aligned}$$

ii. Four characteristics of the image are:

Nature – virtual

Position – 15cm away from the lens, on the same side as the object

Size – diminished

Erect / inverted – erect

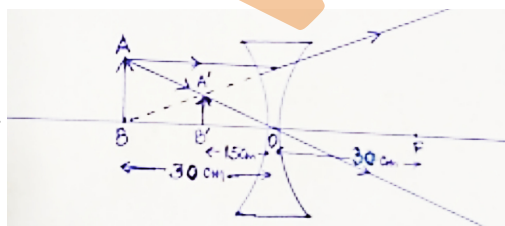

OR

The ability of a lens to converge or diverge light rays is called power of the lens. It is defined as the reciprocal of focal length. Its SI unit is dioptre (D). If focal length is expressed in metres, then power is expressed in dioptre. We can say, dioptre is the power of a lens whose focal length is one metre. For concave lens P and f are negative. For convex lens P and f are positive. Lens A of

focal length + 10 cm is convex lens

$$\text{and power, } P = \frac{100}{f(\text{in cm})} = \frac{100}{10} = +10D$$

Lens B of focal length - 10 cm is concave lens

$$\text{and power, } P = \frac{100}{f(\text{in cm})} = \frac{100}{-10} = -10D$$

Lens A (i.e. convex lens) will form a virtual and magnified image of an object placed 8 cm from it, as shown.

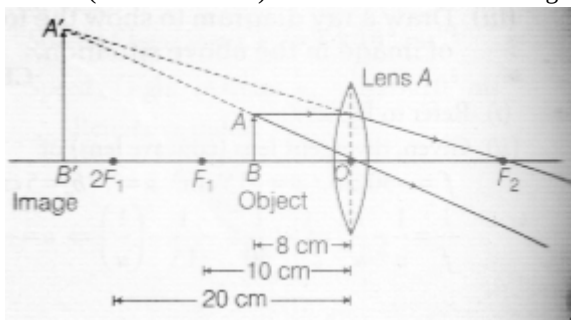

### Section E

#### 37. Read the text carefully and answer the questions:

Copper sulphate crystal contains water of crystallisation when the crystal is heated the water is removed and salt turns white. The crystal can be moistened again with water. The water of crystallisation is the fixed number of water molecules present in 1 formula unit of copper sulphate. On heating gypsum at 373K, it loses water molecules and became calcium sulphate hemihydrate.

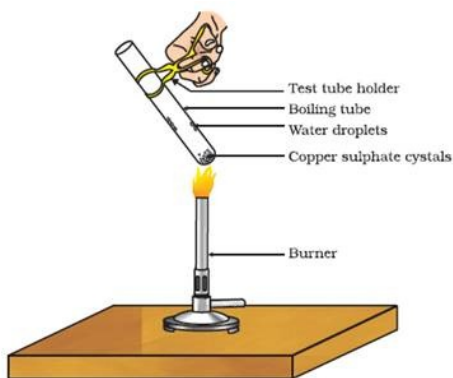

- (i) If the crystal is moistened with water, then the blue colour of the crystal reappears.
- (ii) The commercial name of calcium sulphate hemihydrate is Plaster of Paris.

OR

Five water molecules are present in one formula unit of copper sulphate.

#### 38. Read the text carefully and answer the questions:

Animals have a nervous system for controlling and coordinating the activities of the body. But plants have neither a nervous system nor muscles. So, how do they respond to stimuli? When we touch the leaves of a chui-mui (the 'sensitive' or 'touch-me-not' plant of the Mimosa family), they begin to fold up and droop. When a seed germinates, the root goes down, the stem comes up into the air. What happens? Firstly, the leaves of the sensitive plant move very quickly in response to touch. There is no growth involved in this movement. On the other hand, the directional movement of a seedling is caused by growth. If it is prevented from growing, it will not show any movement.

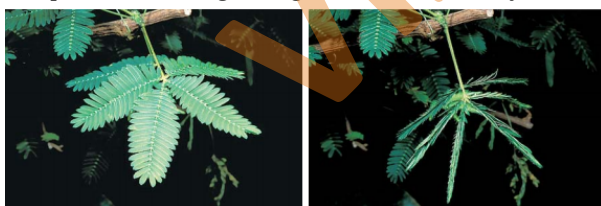

- (i) There are two types of movement:
  - a. dependent on growth
  - b. independent on growth.
- (ii) Auxin is a plant hormone that promotes growth.
- (iii) The function of the nervous system is to control and coordinate the activities of the body.

OR

The movements of the leaves of the sensitive plant are touch sensitive and independent of growth while the movement of the shoot towards light is growth related and known as phototropism.

#### 39. Read the text carefully and answer the questions:

An insulated copper wire wound on a cylindrical cardboard tube such that its length is greater than its diameter is called a solenoid. When an electric current is passed through the solenoid, it produces a magnetic field around it. The magnetic field produced by a current-carrying solenoid is similar to the magnetic field produced by a bar magnet. The field lines inside the

solenoid are in the form of parallel straight lines. The strong magnetic field produced inside a current-carrying solenoid can be used to magnetize a piece of a magnetic material like soft iron when placed inside the solenoid. The strength of the magnetic field produced by a current-carrying solenoid is directly proportional to the number of turns and strength of the current in the solenoid.

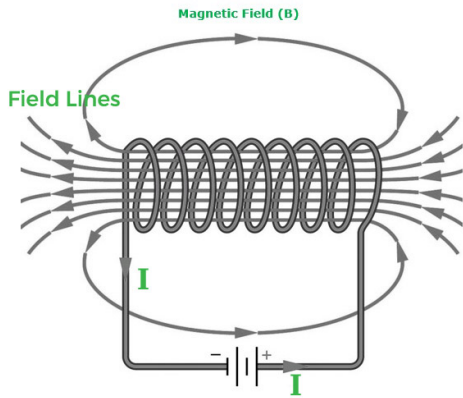

- (i) Magnetic field inside the infinite solenoid is uniform. Hence it is the same at all points.
- (ii) The end of the current carrying solenoid at which the current flows anti-clockwise behaves as a north pole while that end at which the direction of current clockwise behaves as a south pole and this is according to clock wise.
- (iii) For a long solenoid, magnetic field  $B \propto In$ ; where  $I$  is the flowing current and  $n$  is number of turns per unit length in the solenoid. Therefore, in the given case magnetic field will remain unchanged.

OR

For a solenoid, if we imagine gripping the solenoid with your right hand so that your curl fingers follow the direction of the current then your thumb will point towards the north end of the electromagnet.